

Haven Framed Pivot Door

Instruction Manual H5P



PO Box 125, Whitworth Avenue,
Aycliffe Business Park,
Co Durham DL5 6WX

To obtain a copy of the Declaration of Performance for this product, please go to: www.ce-dop.com, contact us on +44 (0) 1325 328034, or write to us at the above address, quoting the product reference number where possible.

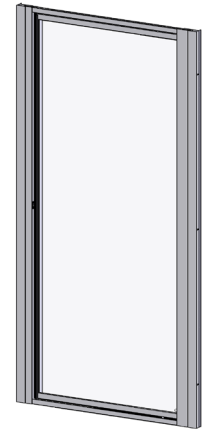

IMPORTANT INFORMATION

Be aware toughened glass can shatter if not handled correctly. It should not be subjected to any sharp impact and it is essential to protect the glass by resting it on a soft protective surface during installation such as cardboard or carpeting. It is recommended to wear PPE at all times during installation.

UK CA



PRE-INSTALLATION CHECKS

1. Check you have the correct product. Please look at the labels on the side of the product packaging.
2. Check all the product components are in the box and the fixing kits.
3. Unpack your product and handle it with care.
4. Please check the product for defects or damage, once the installation has commenced we cannot accept responsibility for any defects or damage.
5. Please take time to read these instructions prior to installing your product.
6. Before you commence any drilling check there are no hidden electrical cables and/or water pipes.
7. No attempt should be made to re-work the toughened safety glass.
8. The installation of the product should be performed by two persons.
9. It is strongly recommended that the walls the product is going to be installed on are vertical.
10. It is strongly recommended the product is fitted on a tiled surface or similar waterproof surface.
11. It is strongly recommended the walls are tiled and grouted before the product is installed.
12. If the walls and/or the tray are not level you will not achieve maximum adjustment of the product.
13. Pictures used are for illustration purposes only, product designs may alter slightly as a result of continuing product development.
14. We do not stipulate where the European Standard Kite Mark should be positioned on the glass when being factory assembled.
15. Please note that some natural misting may occur when you remove this product from its packaging, due to the addition of the glass protection pre-coating. If this does occur this can easily be removed with a soft, dry cloth.

Component Check List: Supplied

Description	Quantity
Wall Profiles	2
Pivot Door Assembly	1
Wall Profile Top Caps	2
Vertical Top Caps	2
Magnet Pairing	1 (Pairing)
Door Bottom Seal	1

Equipment Check List: Not Supplied

Description
4.5mm drill bit (if Installation Procedure B is required)
Electric / Battery Drill
6mm Masonry Drill Bit
Silicone Sealant Gun
Bathroom Sealant
Screwdriver
Spirit Level
Tape Measure
Pencil
Wall Plugs (for Plasterboard if necessary)

Fixing Kit Components

Description	Quantity
2.5mm Drill Bit	1
Wall Plugs (for Brick and Block Only)	6
40mm Screws	6
Coloured Caps and Base Caps	12 (of each)
9mm Screws	6
Branding Badge (where applicable)	1

CONSUMER GUARANTEE

Please make sure the purchaser/end user completes and returns the guarantee card which is enclosed with this product. Failure to validate the Guarantee will mean only the 1 Year Statutory Guarantee will apply.

Step 1 - Preparation

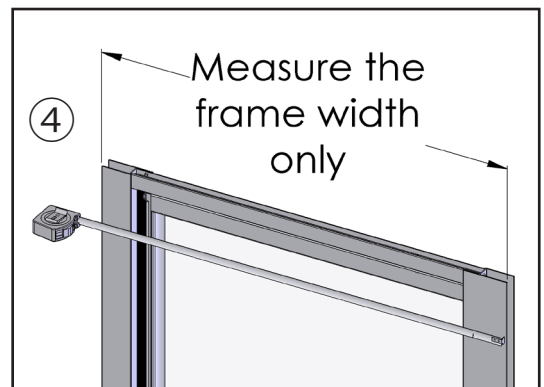
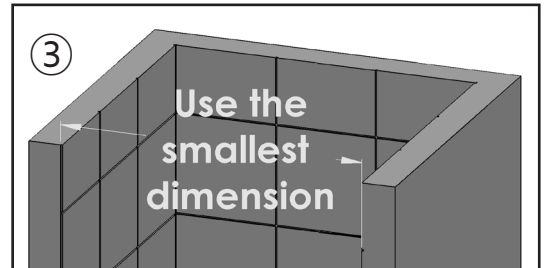
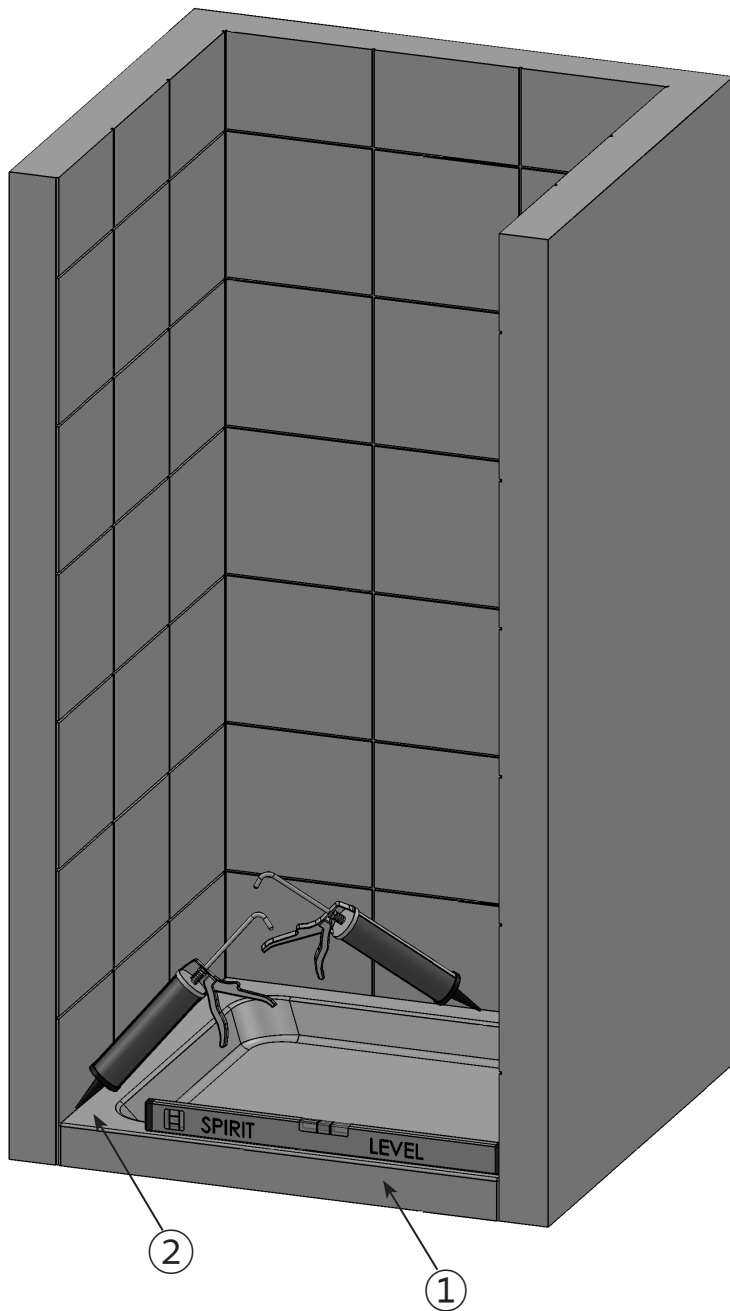

1. Ensure the tray is completely level and check for any movement by standing in it - correct as necessary.
 - Please ensure that the tray is installed as per the manufacturers instructions.
2. Seal the tray fully along the tiled walls prior to installation with a bathroom sealant (not supplied).
 - Prior to fitting the enclosure and when the sealant has fully cured, spray the shower handset over the joints and check for any leaks.
3. Measure the alcove at the top, middle and bottom - note the smallest size as this will be used in stage 4.
4. Measure across the pivot door frame (excluding the wall profiles) and add 55mm to this dimension. If the measurement of the alcove is the same or greater than this dimension then follow Installation Procedure A. If the alcove dimension is smaller than this dimension then follow Installation Procedure B.
 - If using extension wall profiles you will need to add an additional 35mm to the measurements above for each extension wall profile.

Step 2 - Installation Procedure A

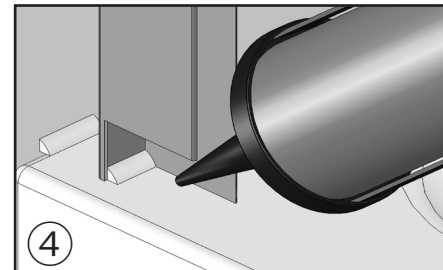
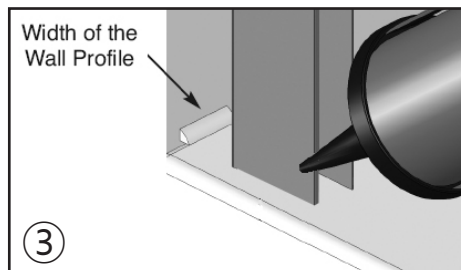
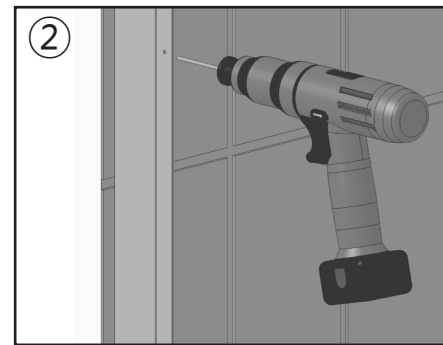
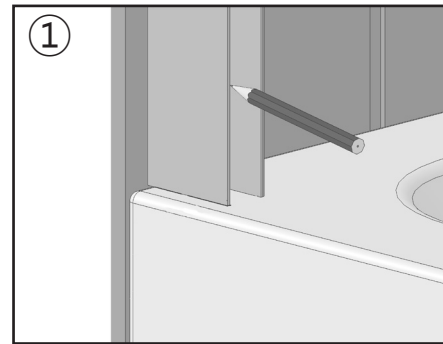
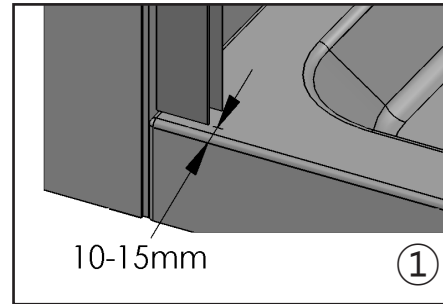
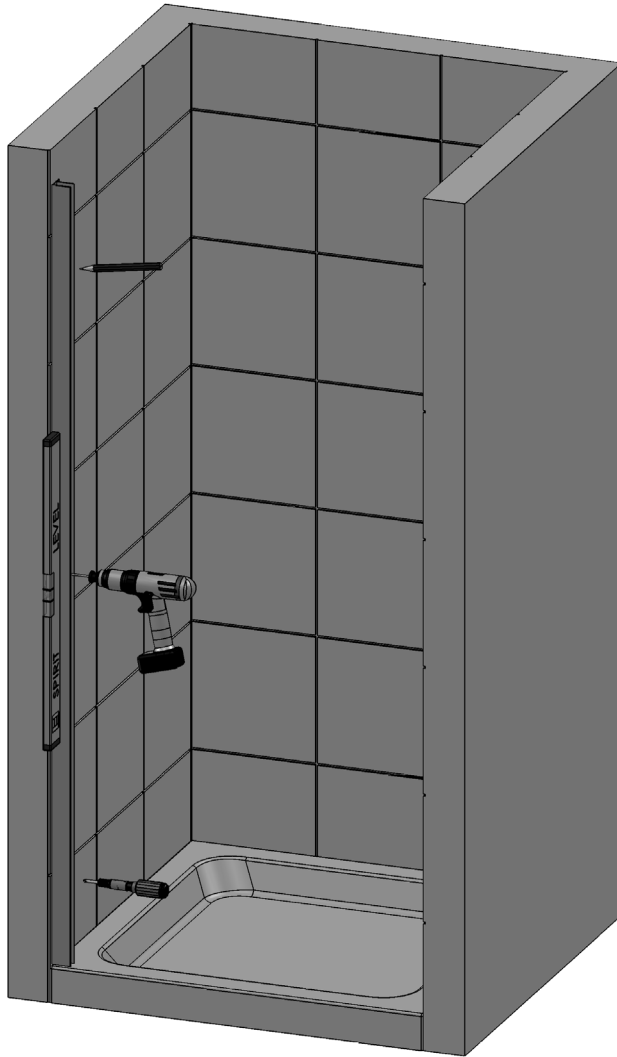

1. Place both wall profiles 10 to 15mm in from the outside of the tray, the lip section of both wall profiles should face inward. Make sure that both wall profiles are completely vertical using a spirit level and mark the wall through the slots with a pencil.
2. Drill the wall with a 6mm masonry drill bit (not supplied) where the Wall Profiles are to be positioned. Fit the wall plugs supplied (if going in to a brick or block wall). If going into a plasterboard wall you will need to purchase appropriate wall fixings. Wipe clear all debris from the Tray before referring to the next stage.
3. Where both wall profiles are to be positioned on the tray, place a bead of bathroom sealant (not supplied) the width of the wall profile along the tiled wall. Screw the wall profiles to the wall with 40mm screws (supplied). Do not over tighten the screws into the wall profiles as this will misshape the wall profile. Ensure the wall profiles stay completely vertical throughout this procedure using a Spirit Level.
 - **No sealant should be present between the wall profiles and the tiled walls vertically prior to screw fixing.**
4. Seal the gap between the tray and wall Profiles with a bathroom sealant (not supplied).
 - **Failure to carry out this procedure correctly can result in serious water damage and is not covered by the Guarantee.**

Step 2A - Installation Procedure A Continued...

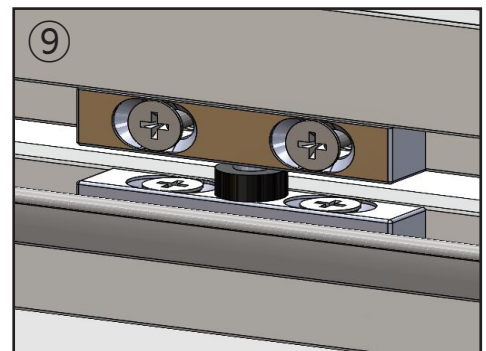
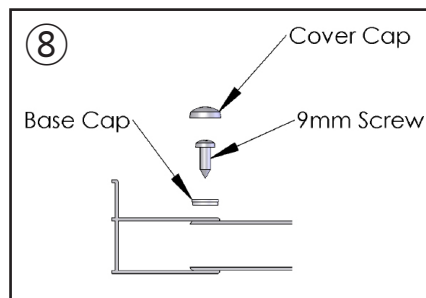
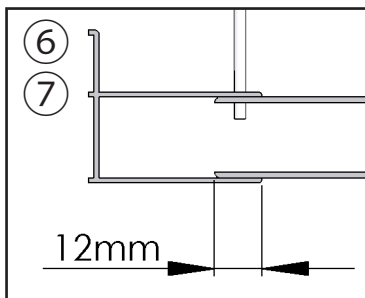
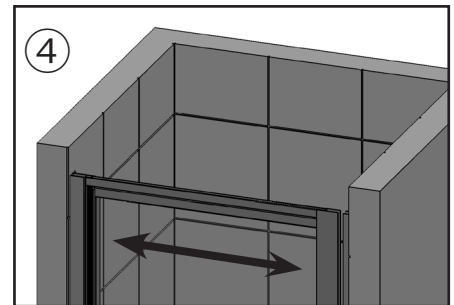
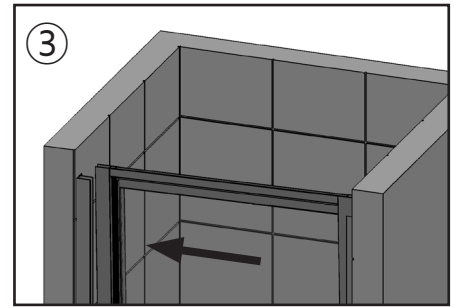
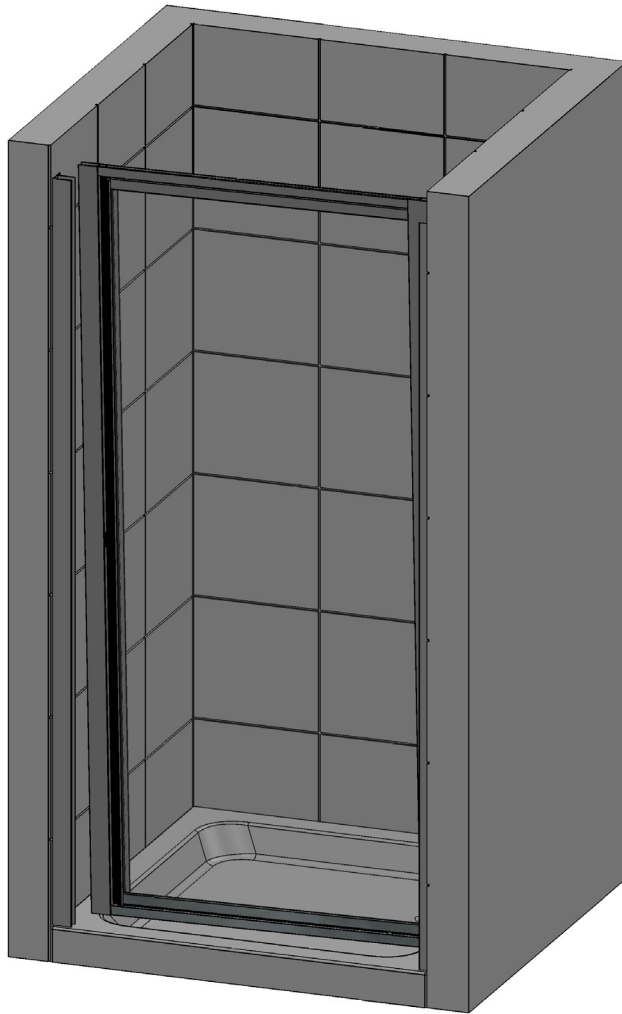

1. With wall profiles fitted, remove pivot door from packaging and cut door banding.
2. Decide whether it is to be left or right hand opening and ensure that the pivot door will open outwards.
3. Slide the pivot door into one of the wall profiles and push it fully home.
4. Once the pivot door is fully inside the wall profile, slide the pivot door back into the other wall profile and ensure that it is equally spaced between both wall profiles.
 - **If using in conjunction with a side, in-line or neo angle panel then refer to the relevant panel instructions.**
5. Adjust the pivot door within its own mainframe ensuring that the gap at the top and bottom of the glass door is parallel, this is to ensure the pivot door opens and closes correctly. To achieve this adjustment push the pivot door mainframe from the top (on the pivot side) further into the wall profile this will ensure the glass door lifts away from the bottom of the pivot door mainframe.
6. Both wall profiles must overlap the pivot door by at least 12mm.
7. Drill 3 holes into each wall profile using the 2.5mm drill bit (supplied) approximately 100mm from the top and bottom and the other in the centre.
8. Fit the 9mm screws into the base caps and screw fix into the recently drilled holes, press fit the cover caps.
9. Adjust the pivot block if necessary in order to get a positive close against the magnets and even gaps between the door and outer frame.

Step 3 - Installation Procedure B

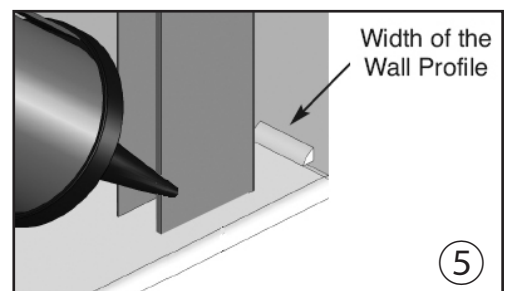
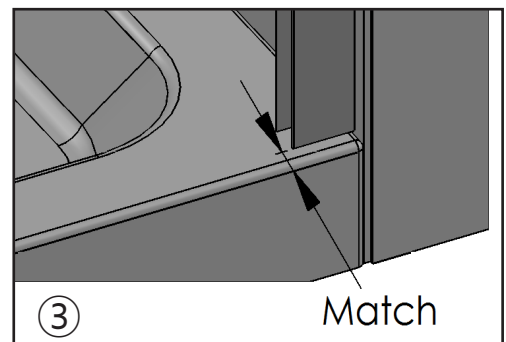
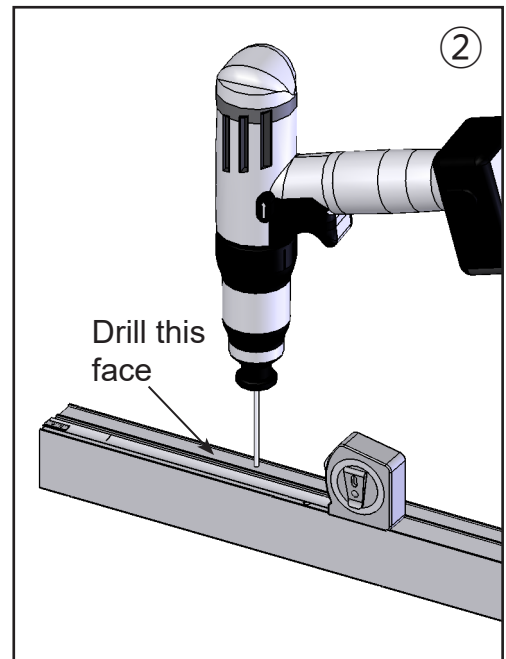
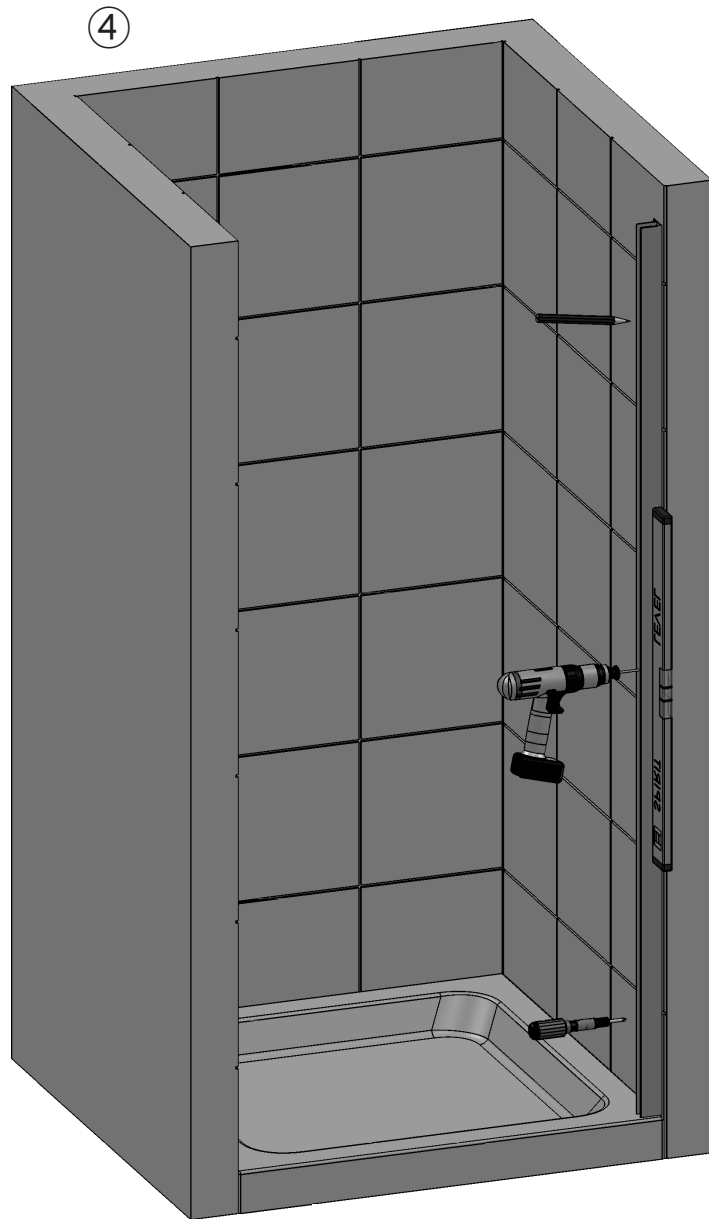

1. Fit one wall profile to the wall as described in stages 1 to 4 of step 2 Installation A.
2. Take the remaining wall profile and drill three 4.5mm holes into the lip, approximately 100mm from each end and the last one positioned in the centre.
 - **Drill the holes through the face that goes to the wall - deburr all holes.**
3. Position the wall profile the same distance in on the tray so that it matches the one fitted in stage 1.
4. With the wall profile completely vertical mark through the newly drilled holes onto the wall and drill and fit the wall plugs as per Step 2 (Installation A), wipe away any debris that is on the tray.
5. Slide the wall profile over the pivot door and slide the other end of the pivot door into the already fixed wall profile, place a bead of sealant between the wall and profile as per stage 3 step 2 (Installation A).
6. Adjust the loose wall profile so that the drilled holes line up with the wall plugs and fix into position on to the wall using the 40mm screws (provided)
 - **Fit the base caps to the 40mm screws in order to fit the cover caps later on.**
7. Follow stages 4 to 9 of step 2A (Installation A) to complete the installation.

Step 4 - Sealing

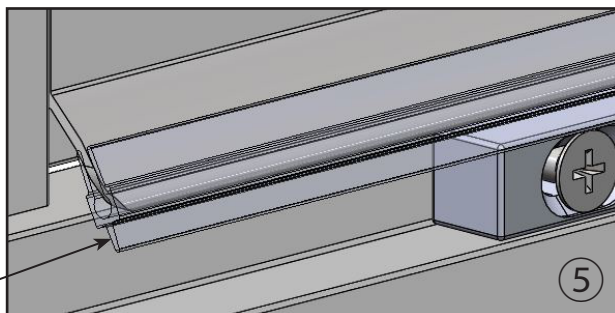
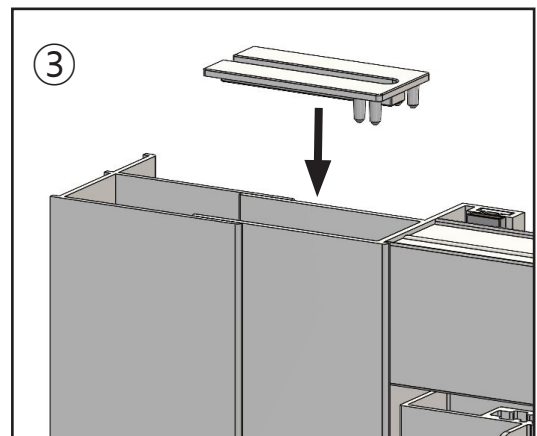
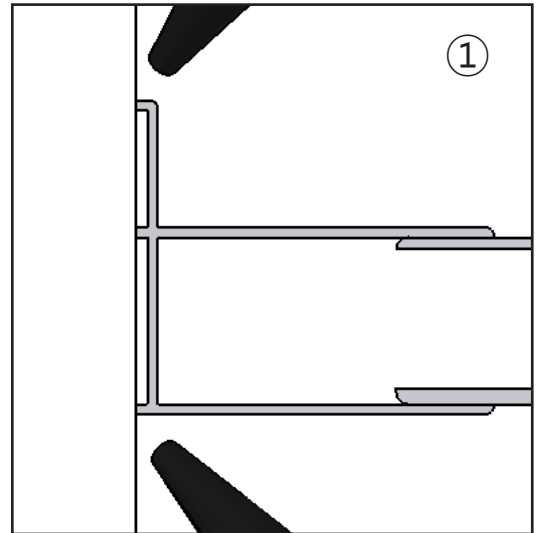
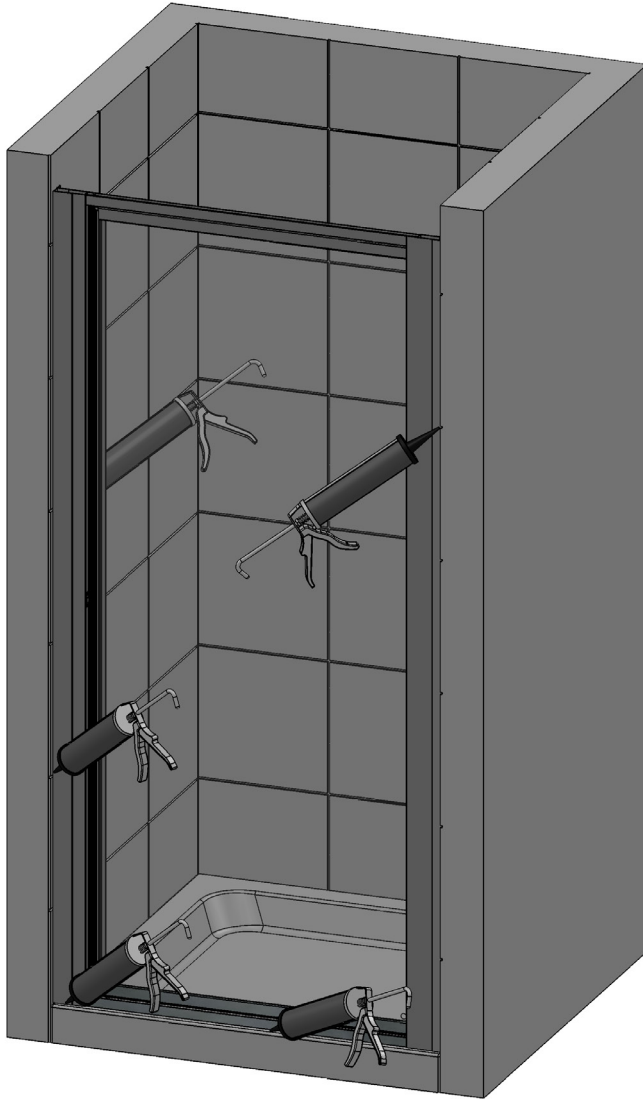

Bottom
Flipper
Seal

1. Seal the wall profile vertically, both internally and externally where they meet the tiles.
2. Seal the base of the enclosure to the top of the tray from wall to wall on the outside only.
 - **Allow 24 hours for the sealant to fully cure prior to using the shower.**
3. Fit the top caps to the top of the pivot door vertical aluminium & wall profiles.
4. Slide the magnet pairing into the door frame and outer frame, the magnets need to be in line with one another in order to ensure a positive close.
5. Fit the linear bottom flipper seal onto the bottom lip of the door frame.
 - **Adjust door accordingly if the bottom seal fouls the outer frame excessively.**
6. Ensure the branding badge (if applicable) is placed prominently on a none moving aluminium part to qualify for your Service Guarantee.
 - **NOTE: If not being used as a steam unit remove the colourless drip seal from both sides of the pivoting point on the top of the glass door.**
 - **The pivot door is an outward opening door which can result in excess water dripping onto the floor outside the shower enclosure when being opened, please ensure care is taken.**

TROUBLE SHOOTING GUIDE

Problem	Solution
Leaking	<ol style="list-style-type: none">1. Check that the inside gap between the Tray and Wall profiles has been sealed correctly.2. Ensure the tray is sealed along the tiled walls prior to installation.3. If the inside joint between the enclosure and the tray top is sealed, this will cause leakage - sealant must be removed.4. Ensure the wall profiles on the tiled walls are sealed both vertically inside and outside.5. Ensure the joint between the enclosure and tray top is sealed.6. Is the bottom seal trim fitted? <p>Important: This enclosure should be water tested conforming to BS EN 14428</p>
Enclosure Alignment on the Tray	<ol style="list-style-type: none">1. Is the enclosure fitted onto a tiled wall?2. Are the wall profiles fitted the same distance from the front outside edge of the tray?3. Are the wall profiles completely vertical?4. (If applicable) is the wall profile fitted in Step 3 set at the same distance as the other.
Door Juddering	<ol style="list-style-type: none">1. Ensure that the gap at the top and bottom of the door is parallel, this will ensure that the door opens and closes correctly (Step 2A).2. Have you taken out the Colourless Drip Seal from the top of the glass door (Step 4).
Door not Closing	<ol style="list-style-type: none">1. Does the door engage the magnet?2. Are the wall profiles completely vertical?3. Is the pivot block adjusted correctly?4. Are the door frames parallel to one another?5. Is the brush seal affecting the door closure? (Remove & refit if needed)

Some important information to help you Maintain your product.

The following information is all you need to keep your product looking new.

Clean your product using a mild detergent diluted in water and then polished off using a soft cloth.

If you live in a hard water area, periodically clean your product using a 50/50 solution of white vinegar and water. The solution should be left on the enclosure for approximately 5 minutes then rinsed off using warm water. This method of cleaning should remove lime scale residue.

Simple Maintenance

Our products are generally maintenance free, however it may be necessary to lubricate wheel assemblies and other moving parts from time to time.

It is strongly recommended that a quality silicone spray is used.

A list of Don't's:

1. Don't use acidic based products which are unsuitable for cleaning enamel surfaces.
2. Don't use abrasive cleaners or cleaners using bleach or solvents, these products will adversely affect the finish of the aluminium profiles.
3. Don't use scouring pads, powder or any sharp instruments when cleaning the enclosure.

Should you experience any problems during installation please refer to the Trouble Shooting Guide or contact Customer Relations on:

+44 (0) 1325 328033

To enable customer relations to provide you with an excellent level of service it is important that you quote your product Code and Reference Number - these can be found on the Guarantee card.